

AMCO INDUSTRIAL VALVES



BALL VALVE - 3 pc Design Regular Port - ANSI Class - 150

DATE: 13 - 06 - 07

REF: DRG. NO. 1006

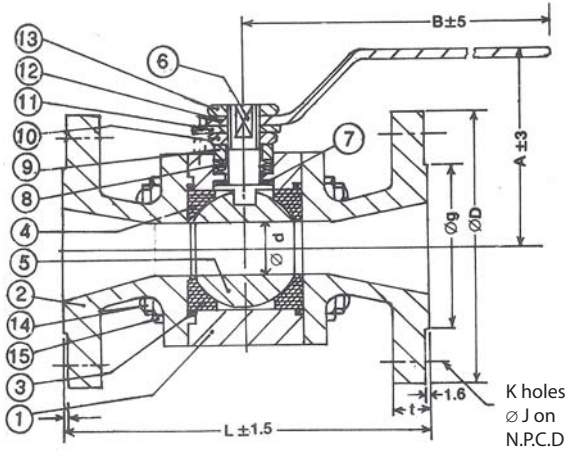

No	Nomenclature	Material							
		ASTM A	ASTM A	ASTM A	ASTM A	ASTM A	Alloy	HAST	HAST
1	Body	ASTM A	ASTM A	ASTM A	ASTM A	ASTM A	Alloy	HAST	HAST
2	End Body Connector	216 WCB	351 CF8	351 CF8M	351 CF3	351 CF3M	20	B	C
3	Body Seal	PTFE							
4	Ball Seat	PTFE - Virgin / Reinforced							
5	Ball	CF 8	CF 8	CF 8M	CF 3	CF 3M	Alloy 20	HAST B	HAST C
6	Stem	AISI 304	AISI 304	AISI 316	AISI 304L	AISI 316L	Alloy 20	HAST B	HAST C
7	Stem Seal	PTFE - Virgin / Reinforced							
8	Gland Packing	PTFE							
9	Gland	AISI 304	AISI 304	AISI 316	AISI 304L	AISI 316L	Alloy 20	HAST B	HAST C
10	Gland Nut	ASTM A 194 GR 2H / SS 304							
11	Stopper / Adaptor	Steel CAD. Plated / EPOXY Powder Coated - Rust Proofed							
12	Lever	Steel EPOXY Powder Coated - Rust Proofed							
13	Lever Nut	ASTM A 194 GR 2H / SS 304							
14	Body Studs	ASTM A 193 GR B7 / SS 304							
15	Body Nuts	ASTM A 194 GR 2H / SS 304							

Manufacturing Standard : BS-5351
 Testing Standard : BS-5146
 Face to Face : ANSI B 16.10
 End Connection : Flanged to ANSI B16.5 RF

a) For sizes 150 and above / optional gear operated

SIZE	15	20	25	40	50	65	80	100	125	150	200	250
A	80	90	100	120	130	140	150	180		225	270	300
B	162	162	190	225	280	280	350	350		475	525	700
L	108	117	127	165	178	190	203	229		267	292	300
∅D	89	98	108	127	152	178	191	229		279	343	406
t	11.1	11.1	11.1	14.5	16	17.5	19.5	24		25.4	28.6	30.2
∅g	35	43	51	73	92	105	127	157		216	270	324
N	60.5	70	79.5	98.5	120.5	140	152.5	190.5		241	298.5	362
K	4	4	4	4	4	4	4	8		8	8	12
∅J	16	16	16	16	19	19	19	19		22	22	25
∅d (Min)	10	13	19	32	38	50	63	76		127	152	202
Wgt. Kg	2.3	2.5	4.0	6.5	10.0	13.6	17.5	22.4				
Qty.												
Tag No.												

Code WCB

Material ASTM A 216

Specification WCB

Test Pressure (BAR)

Shell (Hydrostatic) 30

Seat (Hydrostatic) 21

Seat (Air) 5.5

(All Dimensions in mm)

Customer _____

Order No: _____

Job / Project _____

Manufactured By : **AMCO INDUSTRIAL VALVES**, ROYAPURAM, CHENNAI - 600 013, INDIA.

Due to continuous development programme, the design and data given in this leaflet are subject to change without prior notice.

REV

For Record

For Approval