

AMCO INDUSTRIAL VALVES



BALL VALVE - 'ECONOMISER' SERIES - SCREWED / SOCKET WELD

DATE: 13 - 06 - 07

REF: DRG. NO. 1002

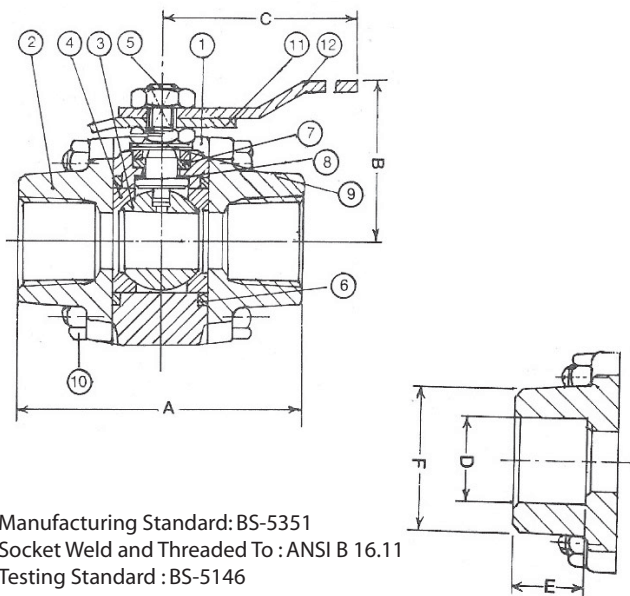

Manufacturing Standard: BS-5351
 Socket Weld and Threaded To : ANSI B 16.11
 Testing Standard : BS-5146

No	Part Name	Material
1	Body	ASTM A 105
2	End Connector	
3	Ball	SS 316
4	Seat	PTFE / Reinforced
5	Stem	SS 316
6	Body Seal	PTFE / Reinforced
7	Gland Packing	
8	Stem Seal	
9	Gland	SS 316
10	Fastener	ASTM A193 - B7 / A 194 - 2 H
11	Stopper	Steel - CAD, Plated / EPOXY Power Coated
12	Hand Lever	EPOXY Powder Coated

SIZE	15	20	25	40	50
A	66.6	72.6	95.2	116	128.0
B	45.0	48.0	59.0	75.0	80.0
C	114.0	114.0	146.0	178.0	178.0
D	21.72 / 21.97	27.3 / 27.05	34.03 / 33.78	48.9 / 48.64	61.11 / 61.36
E	9.7	12.7	12.7	12.7	15.90
F	27.0	32.5	40.0	55.0	68.0
Wgt. Kg.	.680	.840	1.500	2.850	4.050
Qty.					
Tag No.					

Code	ASTM				
Material	A 105				
Specification :	ASTM				
* Test Pressure (Bar)					
Shell (Hydrostatic)	104				
Seat (Hydrostatic)	69				
Seat (Air)	5.5				
*Steam Ratings					
Saturated Steam Pressure (Bar)	31.0	29.0	27.5	22.0	20.5
Corresponding temp. °C	237	235	231	220	218

(All Dimensions in mm)

Customer _____
 Order No: _____
 Job / Project _____

Manufactured By : **AMCO INDUSTRIAL VALVES, ROYAPURAM, CHENNAI - 600 013, INDIA.**

Due to continuous development programme, the design and data given in this leaflet are subject to change without prior notice.

REV

For Record

For Approval