

AMCO INDUSTRIAL VALVES

DISC CHECK VALVES

DATE : 21.03.07

REF: DRG.NO.DCV15-100

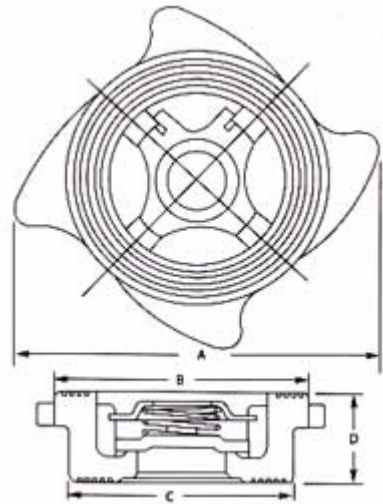
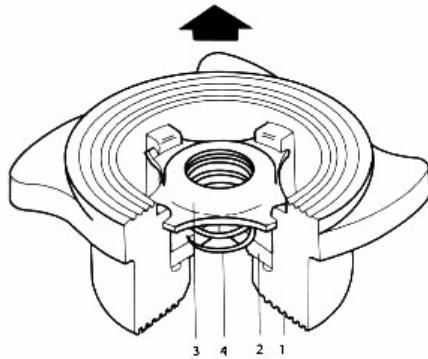

REV

NO	PART NAME	SPECIFICATION
1	BODY	ASTM A 351 Gr.CF8M / 316
2	DISC	316
3	SPRING RETAINER	316
4	STANDARD SPRING	316
	HEAVY DUTY SPRING	316

Opening pressures in mbar

Differential pressures with zero Flow

➔ Flow Direction

DN	15	20	25	32	40	50	65	80	100
↑	25	25	25	27	28	29	30	31	33
➔	22.5	22.5	22.5	23.5	24.5	24.5	25	25.5	26.5
↓	20	20	20	20	20	20	20	20	20

Where lowest opening pressures are required valves without springs can be installed in vertical pipes with bottom - to - top flow.

Without spring

↑	2.5	2.5	2.5	3.5	4	4.5	5	5.5	6.5
---	-----	-----	-----	-----	---	-----	---	-----	-----

Standard of shut off

Standard valves conform to DIN 3230 Part. BN 2. Soft Seated versions give zero leakage provided a differential pressure exists.

Note : Disc Check Valves are not suitable for use where heavily pulsating flow exists, such as close to a compressor.

SIZE	A	B	C	D	Wt/kg
DN15	60	43	38	16	0.11
DN20	69.5	53	45	19	0.17
DN25	80.5	63	55	22	0.28
DN32	90.5	75	68	28	0.47
DN40	101	85	79	31.5	0.64
DN50	115	95	93	40	1.11
DN65	142	115	113	46	1.64
DN80	154	133	128	50	2.21
DN100	184	154	148	60	3.31

All Dimensions are in mm.

Designed and manufactured in accordance with BS 7438.

Sizes and pipe connections

DN 15, 20, 25, 32, 40, 50, 65, 80, 100

Disc Check valves can be fitted between BS : 10 Table 'E' and 'H', BS : 4504 / DIN PN 6, 10, 16, 25, 40, JIS 5, 10, 16, 20, ASA 150 , 300 flanges with the following exception. DN 40, 50, 80 and 100 - will not fit between JIS 5 flanges. DN 65 and 80 - will not fit between BS : 10 Table 'E' flanges.

Limits: Maximum body design PN 40
 PMO - Maximum operating pressure 40 bar g
 TMO - Maximum operating temperature
 300° C with standard / heavy duty spring
 400° C without spring
 Maximum cold hydraulic test 60 bar g
 Minimum operating temperature - 500°C

FOR RECORD

FOR APPROVAL

CUSTOMER : _____

ORDER NO : _____

JOB/PROJECT : _____

MANUFACTURED BY : AMCO INDUSTRIAL VALVES, CHENNAI - 600 013.