

AMCO INDUSTRIAL VALVES



Globe Valve Class - 600

DATE: 13 - 06 - 07

REF: DRG. NO GLV - 600

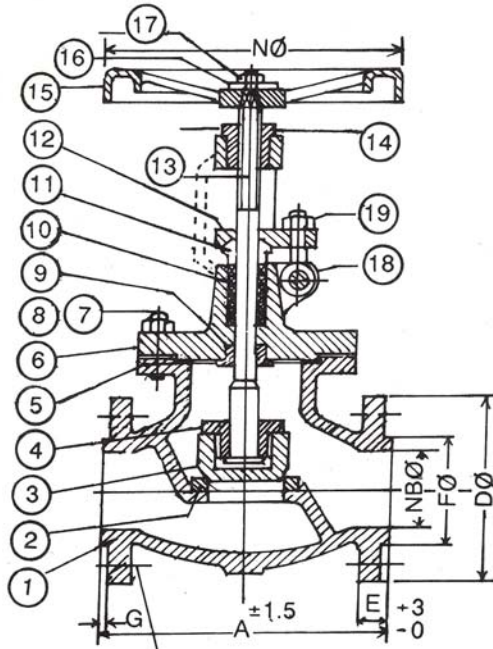

'H' Nos 'K' Ø Holes On
'M' P.C.D Drilled Off Centre
Equispaced

No	Part Name	Qty	Material Specification
1	Body	1	ASTM A 216 Gr. WCB ASTM A 351 Gr. CF 8 / CF 8M / CN 7M
2	Seat Ring	1	Carbon Steel with 13% Cr. for alloy steel integral seat.
3	Disc	1	AISI 410 / S. S. 304 / S. S. 316 / A 20
4	Spindle Nut	1	AISI 410 / S. S. 304 / S. S. 316 / A 20
5	Body Seal	1	S. S. Spiral Wound
6	Bonnet	1	ASTM A 216 Gr. WCB ASTM A 351 Gr. CF 8 / CF 8M / CN 7M
7	Body Stud	As Req.	Carbon Steel ASTM A 193 B7
8	Body Stud's Nut	As Req.	Carbon Steel ASTM A 194 2H
9	Back Seat Bush	1	AISI 410 Integral Seat for Alloy Steel
10	Gland Packing	7 min	Asbestos LUB
11	Gland	1	AISI 410 / 304 / 316 / A 20
12	Gland Flange	1	Carbon Steel / S. S. 304
13	Spindle	1	AISI 410 / 304 / 316 / A 20
14	Yoke Nut	1	AL Bronze / Ni Resist
15	Hand Wheel	1	Cast Iron / Malleable Iron
16	Washer	1	Carbon Steel
17	Hand Wheel Nut	1	Carbon Steel
18	Cross Bolt Nut	2/2	Carbon Steel
19	Gland Bolt Nut	2/2	Carbon Steel

Primary Service Rating

Class	Pressure	Temperature
600	600 PSIG / 105 Kg / cm ² (g)	850 °F (450 °C)

Applicable Class 600 Standards : Steel Valves - ANSI B16.34 -1977 Standard Class
Face to Face ANSI B16.10, End. Flanges ANSI B16.5
Manufacturing Standards - BS - 1873. Testing Standards API / 598

NB	40	50	65	80	100	150	200	250	300
A	241	292	330	356	432	559	660	787	838
D	156	165	190	210	273	356	419	508	559
E	22	25	28	32	38	48	56	64	67
F	73	92	105	127	157	216	270	324	381
G	6.4	6.4	6.4	6.4	6.4	6.4	6.4	6.4	6.4
H	4	8	8	8	8	12	12	16	20
K	22	19	22	22	25	28	32	35	35
M	114	127	149	168	216	292	349	432	489
N	178	203	254	254	305	457	508	610	762
Wgt. Kg									
Qty.									
Tag No.									

Code	WCB
Material	ASTM A 216
Specification	WCB
Test Pressure	
Shell (Hydrostatic)	153 Kg / cm ²
Seat (Hydrostatic)	105 Kg / cm ²
Seat (Air)	5.5 Kg / cm ²

(All Dimensions in mm)

Customer _____
Order No: _____
Job / Project _____

Manufactured By : **AMCO INDUSTRIAL VALVES**, ROYAPURAM, CHENNAI - 600 013, INDIA.

Due to continuous development programme, the design and data given in this leaflet are subject to change without prior notice.

REV

For Record

For Approval